

Dikkat

- 1- Resim üzerinden ölçü aleti ile ölçü almayın.
- 2- Formu veya ölçüsü değişen resimleri teknik büroya bildirin.
- 3- Resim üzerinde kontrol edenin başkası değişikliği yapamaz.

Attention

- 1- Do not take measurements with the measurement tool.
- 2- Inform the technical office of the pictures that have changed form or size.
- 3- The image cannot be changed by anyone other than the person who controls it.

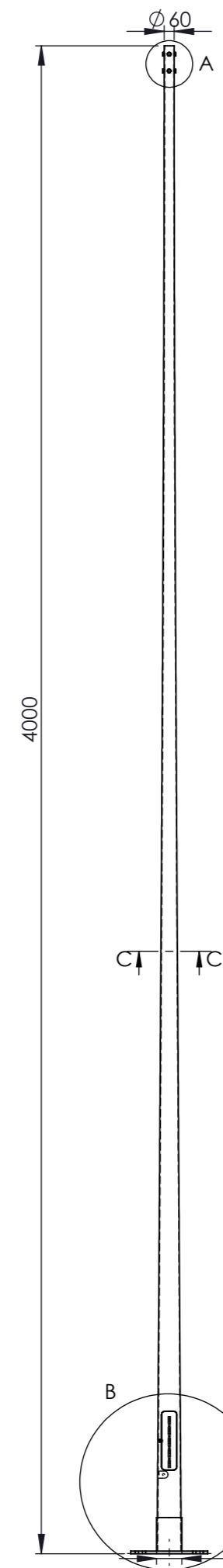

t=3mm

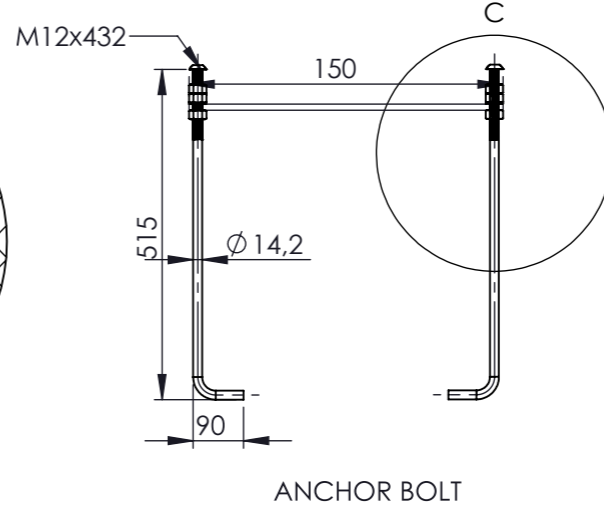
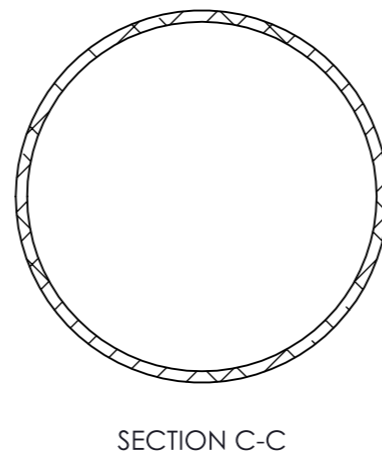
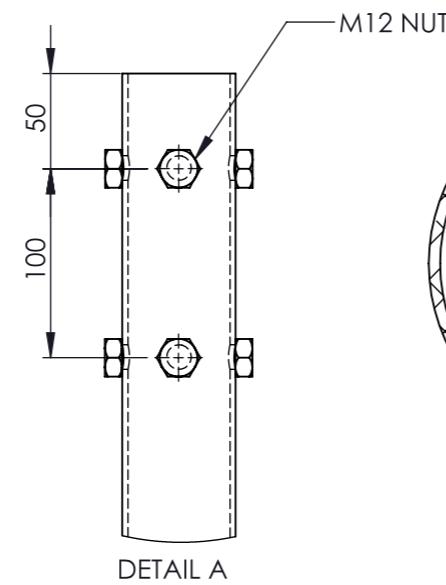

END CAP FOR ANCHOR BOLTS (4PCS)

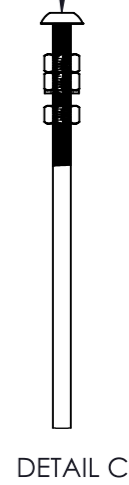

C-C

RAIL FOR FIXING THE CONNECTION BOX

METAL PLATE SUPPLIED WITH BOLT AND NUT FOR FIXING THE SUPPLY CABLE

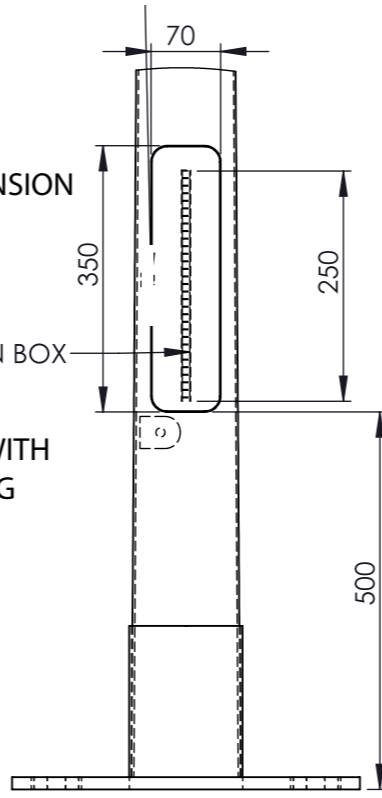

DETAIL B

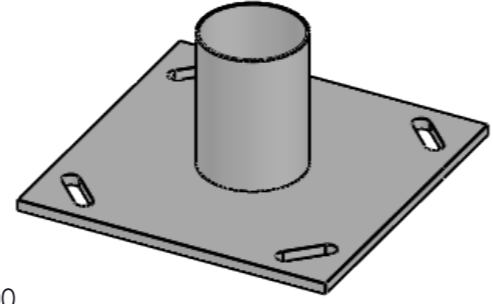
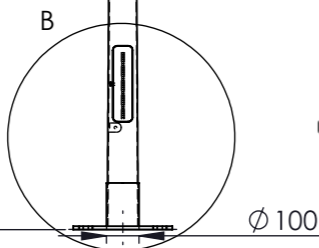
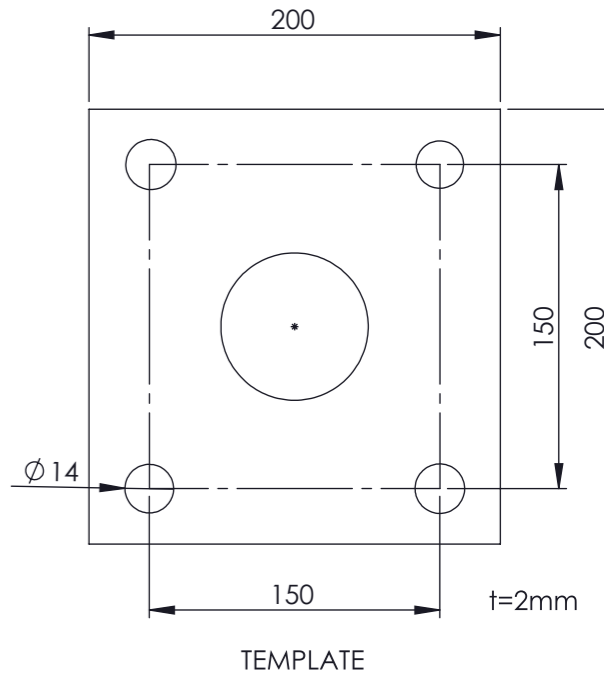
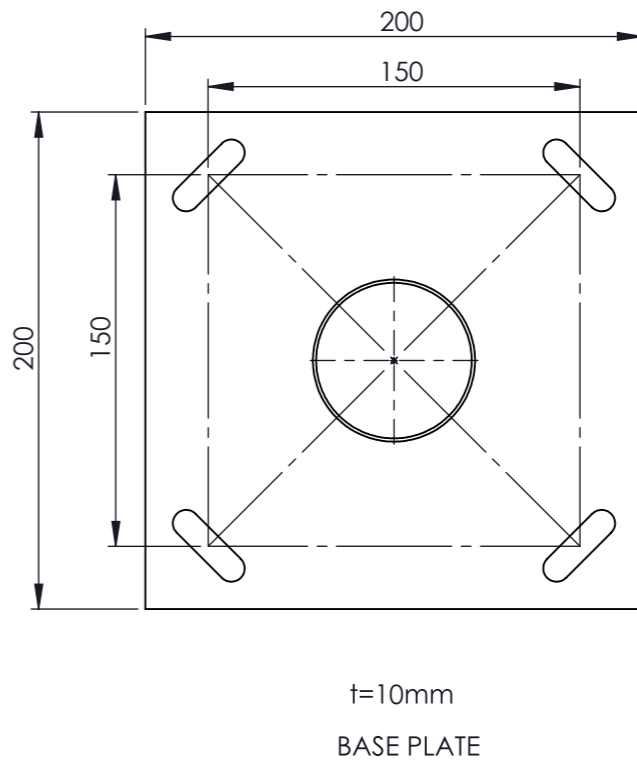

ADI - SOYADI NAME - SURNAME	TARİH DATE	İMZA SIGN	MALZEME MATERIAL	MALZEME STANDARTI MATERIAL STANDARD	REVİZYON NO REVISION NO	SAYFA NO PAGE NR
ÇİZEN DRAWN BY	Özkan EBİL	27.04.2022	ST37 (S235 JR)	EN 10025		1/1
KONTROL CONTROL	Eray YILDIRIM	27.04.2022	ANKRAJ KALİTESİ ANCHOR BOLTS GRADE	DİREK STANDARTI LIGHTING COLUMNS STANDARD		
ONAY APPROVAL	Zafer KORKMAZ	27.04.2022	1040 STEEL	EN 40		
ÖLÇEK SCALE	1:100		SICAK DALDIRMA GALVANİZ STANDARTI HOT DIP GALVANIZATION STANDARD			
GENEL NOTLAR GENERAL NOTES			EN ISO 1461/ASTM A123		RESİM NO DRAWING NO	ANET FORMAT
TÜM ÖLÇÜLER mm'DİR. ALL DIMENSIONS ARE IN mm. ELEKTROSTATİK TOZ BOYALI OLACAKTIR ELECTROSTATIC POWDER PAINT			IS-HO-K-60/40-3 Hot Dipped Galvanized Conical Pole 4M		E21-R1	A3

DOSYAYI SON KAYDEDEN: pROJE1
SON KAYIT TARİHİ : 28.04.2022

Dosya adı: 4M POLE